

SLAB NOTE SDG-1  
 6" MIN. NORMAL WEIGHT CONCRETE SLAB-ON-GRADE  
 REINFORCED WITH #4@15" OC EACH DIRECTION.  
 CRUSHED STONE SUBBASE ON COMPACTED SUBGRADE.

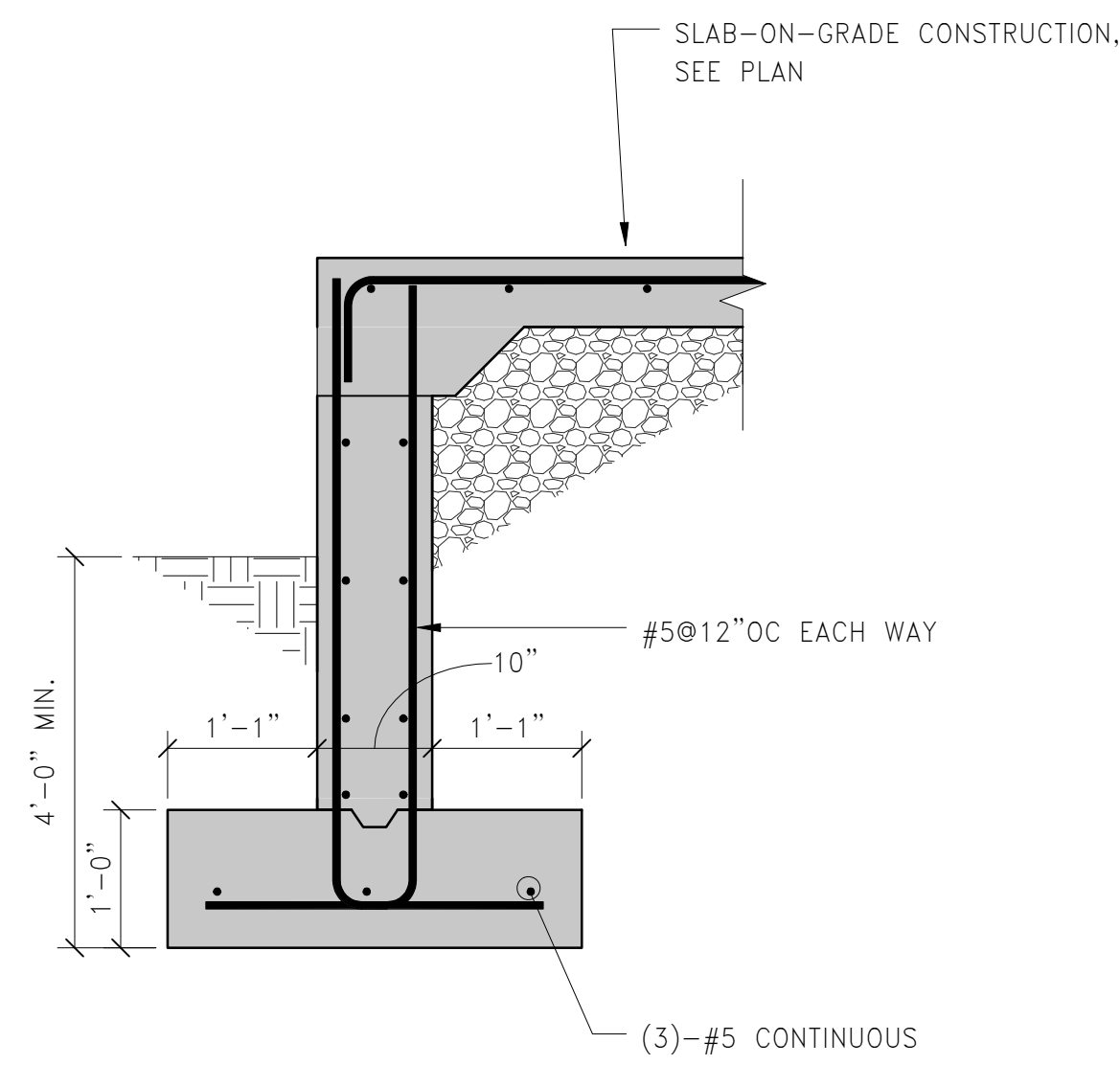

BUILDING 2 LEVEL 3 LOADING DOCK PLAN  
 1/4" = 1'-0"

1 SECTION  
 3/4" = 1'-0"

**MPA** MARGULIES PERRUZZI ARCHITECTS  
 388 Congress Street | Boston, MA 02210 | 617.482.2322 | www.mpa-architects.com  
 Design for the way you work.

CLIENT INFORMATION  
**AS CLOCK TOWER**  
 OWNER, LLC c/o  
 SARACEN  
 PROPERTIES  
 MILL & MAIN  
 RENOVATION  
 PHASE 1  
 146 MAIN STREET  
 MAYNARD, MA 01754

CONSULTANT INFORMATION  
 MECH ENGINEERS  
**WELLS ENGINEERING**  
 24 HAWTHORNE AVE., 3RD FLOOR  
 LYNN, MA 01901  
 781.337.3200  
 HARDWARE CONSULTANT  
**CAMPBELL-MCCABE, INC.**  
 1 LOCKWOOD AVE., 2ND FL  
 WILMINGTON, MA 01974  
 781.899.8822  
 CIVIL ENGINEERS  
**MAKIN ASSOCIATES**  
 100 WASHINGTON ST., #2  
 WASHINGTON, MA 01890  
 617.964.5177  
 LANDSCAPE DESIGN  
**BROWN, RICHARDSON, & ROWE**  
 800 WASHINGTON AVE., 3RD FLOOR  
 BOSTON, MA 02109  
 617.542.8852  
 LIGHTING CONSULTANT  
**SLADEN FENSTEIN INTEG.**  
 250 WASHINGTON AVE., # 305  
 BOSTON, MA 02119  
 617.267.9500  
 GEOTECHNICAL CONSULTANT  
**HALEY & ALDRICH, INC.**  
 405 MEDFORD STREET, SUITE 2000  
 BOSTON, MA 02129  
 617.856.7591

| REVISIONS |             |      |
|-----------|-------------|------|
| NUMBER    | DESCRIPTION | DATE |
|           |             |      |

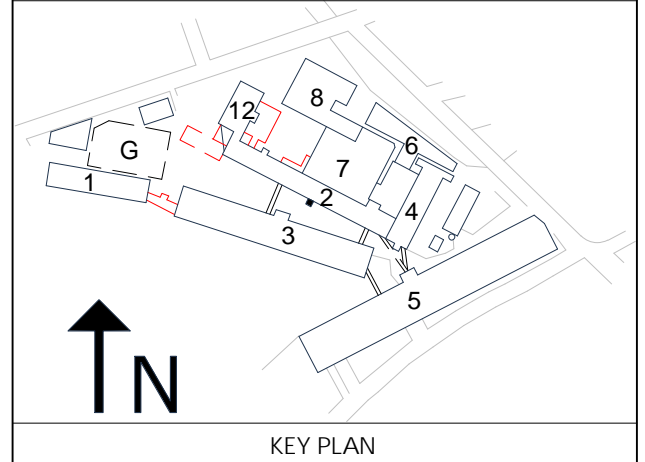
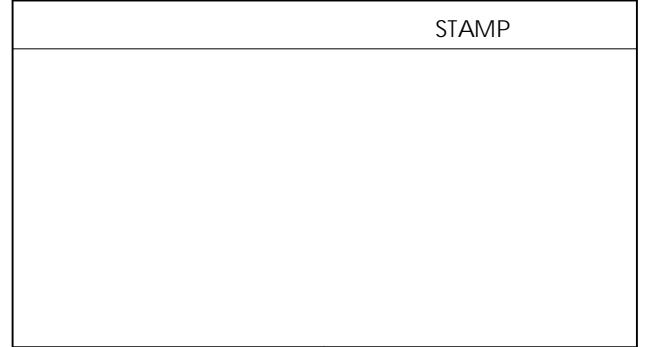

KEY PLAN  
 DATE: 10/19/2015  
 SCALE: As Indicated  
 DRAWN BY: MSS  
 PROJECT NUMBER: SAR15A.00  
 DRAWING TITLE  
**LEVEL 3 - LOADING DOCK PLAN**

**2S-101**  
 DRAWING NUMBER